

AT&T Hosted Voice Service (HVS)

RAY BAUM COMPLIANCE

Part 10: Emergency Services for Microsoft Teams

December 2021

AT&T HVS 911 Update – Ray Baum Act Compliance Training Webinars



Training Videos, Webinars, & Presentation Downloads Available at
www.clearspancloud.com/att-admin-training

OpEasy™ v21.x Documentation Available at
www.clearspancloud.com/admin_opeasy_training

AT&T HVS 911 Update – Ray Baum Act Compliance Training

- Part 1: Overview of Ray Baum Act and Kari's Law Requirements
- Part 2: Clearspan Compliance Recommendation
- Part 3: Dispatchable Locations and Emergency Response Locations
- Part 4: Importing ERLs from Existing Intrado ERS Account to OpEasy
- Part 5: OpEasy™ creating Intrado ERLs
- Part 6: OpEasy™ assigning ERLs to Non-HELD capable SIP wired endpoints
- Part 7: OpEasy™ and HELD enabled SIP Wired Endpoints
- Part 8: Soft Clients on Computers (Nomadic Devices) – Intrado Location Manager
- Part 9: Soft Clients on Mobile Devices
- **Part 10: Emergency Services for MS Teams**

Part 10:

Emergency Services for Microsoft Teams

Supported HELD Capable SIP Wired End Points

ERS AND LIS PROTOCOLS

This part of the Ray Baum compliance training is focused on the ability of a MS Teams client to detect information about its network connection and then request the dispatchable location for that network connection

Microsoft provides a Location Information Service (LIS) to provide dispatchable location information for MS Teams clients.

When the MS Teams client starts and/or the client detects connection to a new IP address or a new WiFi BSSID, the client will send a request to the MS LIS to acquire new dispatchable location information for 911 calls based on the network location. The network location can be identified at a subnet level, switch chassis level, switch port level, or WiFi BSSID level. Typically, your IT department is responsible for provisioning the MS LIS.

This dispatchable location information provided to the client contains the geo-coordinates (longitude & latitude), the postal address, and additional location information like floor and office number.

This location information will be included in 911 calls from the MS Teams clients.

HELD Enabled Wired Devices

LLDP QUERY TO ACQUIRE NETWORK LOCATION INFORMATION

- 1 When the MS Teams client starts or detects a network connectivity change, the client will query the connected network equipment
- 2 In a wired mode, the Chassis response includes Chassis ID and Port ID, Wi-Fi is based on the access points BSSID
- 3 The MS Teams client sends the network information to MS Location Information Server (LIS) via a HELD request
- 4 MS LIS indexes the location database and returns location information via HELD response

MS Location Information Service (LIS)

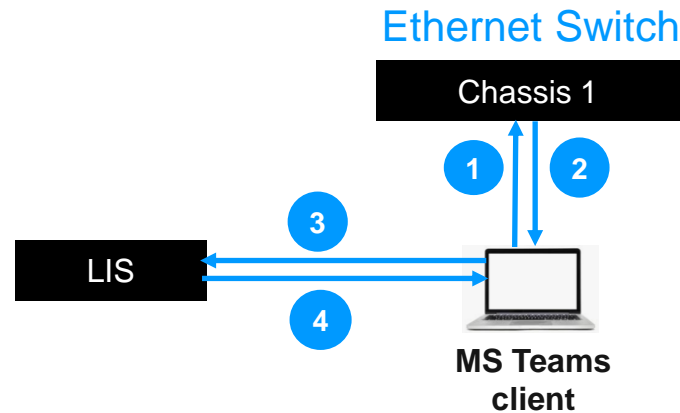

TLV type values^[5]

TLV type	TLV name	Usage in LLDPDU
0	End of LLDPDU	Mandatory
1	Chassis ID	Mandatory
2	Port ID	Mandatory
3	Time To Live	Mandatory
4	Port description	Optional
5	System name	Optional
6	System description	Optional
7	System capabilities	Optional
8	Management address	Optional
9-126	Reserved	-
127	Custom TLVs	Optional

HELD Enabled Wired Devices



HELD REQUEST FROM THE MS TEAMS CLIENT TO THE MS LIS

Example for Civic

In the following HELD Request, the “LocationType” parameter is provided as “civic”. Hence, the response returns the entire civic address and the geo-coordinates of the phone.

Request

```
<?xml version="1.0" encoding="UTF-8"?>
<locationRequest xmlns="urn:ietf:params:xml:ns:geopriv:held">
  <locationType exact="false">civic</locationType>
  <device xmlns="urn:ietf:params:xml:ns:geopriv:held:id">
    <mac>64-16-7f-1b-85-e6</mac>
    <ip v="4">192.168.6.101</ip>
    <ChassisID>AgcEiFqSaoqA</ChassisID>
    <PortID>BAkFR2kyLzAvMTc=</PortID>
    <nai>5147451111@192.168.10.190</nai>
  </device>
  <CompanyID>DAFAF95E-B3E7-42E8-B98D-F464E084411F</CompanyID>
</locationRequest>
```

MS Teams client request to the MS LIS

HELD Enabled Wired Devices



HELD RESPONSE FROM THE MS LIS TO THE MS TEAMS CLIENT

Response

```
<?xml version="1.0" encoding="UTF-8"?>
<locationResponse xmlns="urn:ietf:params:xml:ns:geopriv:held">
  <presence xmlns="urn:ietf:params:xml:ns:pidf"
    xmlns:ca="urn:ietf:params:xml:ns:pidf:geopriv10:civicAddr"
    xmlns:gml="http://www.opengis.net/gml"
    xmlns:gp="urn:ietf:params:xml:ns:pidf:geopriv10"
    xmlns:gs="http://www.opengis.net/pidflo/1.0" entity="pres:www.west.com">
    <tuple id="lisLocation">
      <status>
        <geopriv>
          <location-info>
            <gs:Point>
              <gml:pos><b>40.511779 -74.249721</b></gml:pos>
            </gs:Point>
            <ca:civicAddress xml:lang="en">
              <ca:country>0</ca:country>
              <ca:A1><b>NY</b></ca:A1>
              <ca:A3><b>MANHATTAN</b></ca:A3>
              <ca:RD><b>Main St</b></ca:RD>
              <ca:HNO><b>122</b></ca:HNO>
              <ca:LOC />
              <ca:NAM><b>Office</b></ca:NAM>
              <ca:PC><b>10307</b></ca:PC>
            </ca:civicAddress>
          </location-info>
          <usage-rules
            xmlns:gbp="urn:ietf:params:xml:ns:pidf:geopriv10:basicPolicy">
            <gbp:retransmission-allowed>true</gbp:retransmission-
allowed>
              <gbp:retention-expiry>2020-07-
03T09:35:32.803625</gbp:retention-expiry>
            </usage-rules>
            <method><b>Wiremap</b></method>
          </geopriv>
        </status>
        <timestamp>2020-07-02T09:35:32.803625</timestamp>
      </tuple>
    </presence>
  </locationResponse>
```

MS LIS response to the MS Teams client

The format of the location information is known as PIDF-LO
(Presence Information Data Format Location Object)

MS Teams clients require an Intrado MS Teams Deployment Account. Intrado is responsible for creating the Intrado MS Teams accounts. The account will have a unique account ID that needs to be provisioned in OpEasy by the Clearspan OPS team via a support ticket that includes the new account ID.

Also, Intrado requires a unique FQDN for MS Teams users to be able to identify the correct Intrado MS Teams account to use for 911 calls. AT&T provides the domain information to Intrado and the Clearspan OPS team addresses this through OpEasy system accounts.

Since each MS Teams client has unique location information that is included in 911 calls, OpEasy only needs to provision 10 digit DID numbers in the Intrado ERS MS Teams database for each MS Teams user.

Overview of Ray Baum Requirements

DISPATCHABLE LOCATION AND EMERGENCY RESPONSE LOCATION

The dispatchable location will be provided by the MS LIS service to the MS Teams client

The Intrado ERS service will route the call based on the geocoordinates received with the 911 call

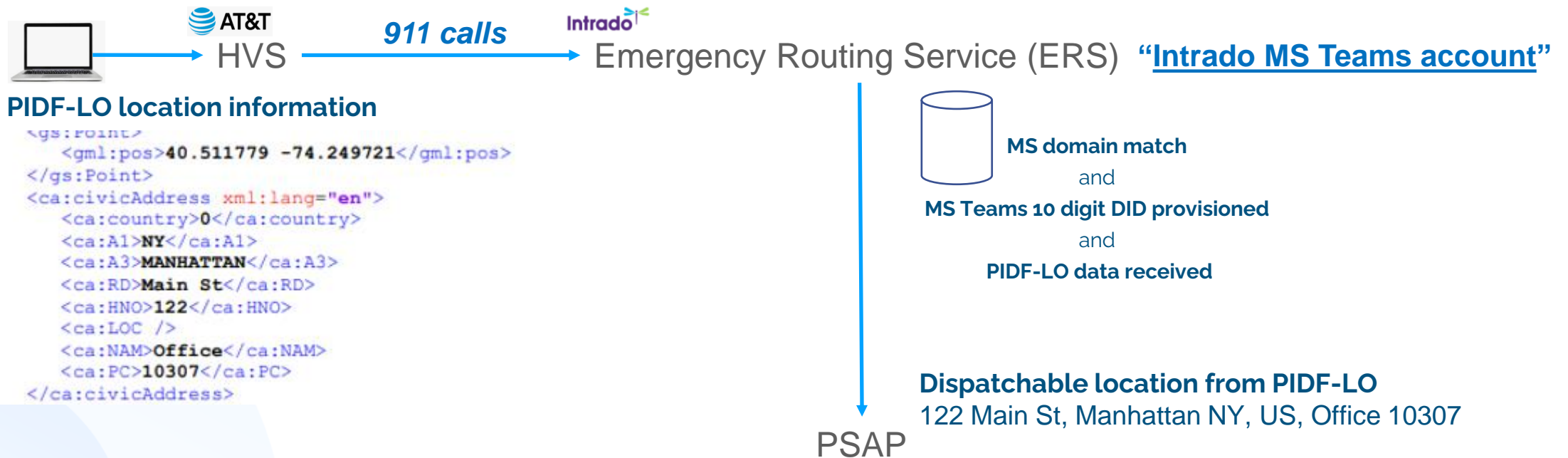

Supported HELD Capable SIP Wired End Points

ERS AND LIS PROTOCOLS

It is important to note that the LIS function may not be available for MS Teams clients that are off-net (i.e. home office)

AT&T Hosted Voice Service (HVS)

RAY BAUM COMPLIANCE

THANK YOU

